

# T Technical Specifications



Traditional values are important to us at TDM. Values like craftsmanship, quality, integrity and a genuine concern for our environment. We're proud of our doors because they embody these values and more.

Today's market demands that our modern technological skills are equal to our heritage of craftsmanship. So we build doors that not only look good, but are functional in every aspect of design, purpose and cost-effectiveness.

As leaders in the door-making business, it therefore gives us much pleasure to present this brochure as a source of reference and inspiration to help you in choosing the doors which best suit your application.

At TDM we offer you the best of both worlds — Traditional values. Tomorrow's technology.

## TECHFORM<sup>®</sup> Engineered Timber Products

Techform<sup>®</sup> is a TDM approach that combines the natural properties of timber with the best technology available to produce a door that looks and feels like solid timber without sacrificing performance.

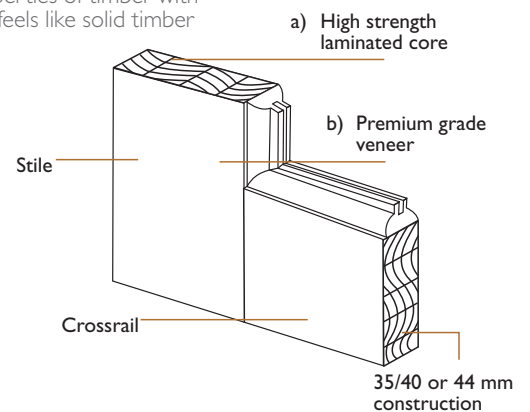
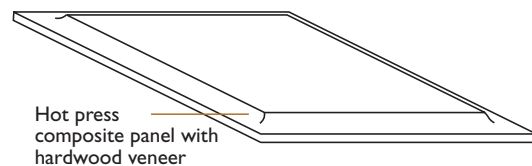

The scientific process used in manufacturing Techform<sup>®</sup> doors results in a stile that remains true and will not warp, shrink, crack or twist.

Techform<sup>®</sup> doors are engineered using a solid internal core of laminated timber lengths. This gives a uniform stile and cross-rail construction that ensures maximum strength and stability.

The exposed surface is then covered with premium grade veneer.

Two of the main advantages of Techform<sup>®</sup> are found in the doors' appearance and performance. The use of veneered components ensures consistent colour matching while the engineered components deliver superior performance.



# FLUSH PANEL DOOR CONSTRUCTION

## HOLLOW CORE DOOR

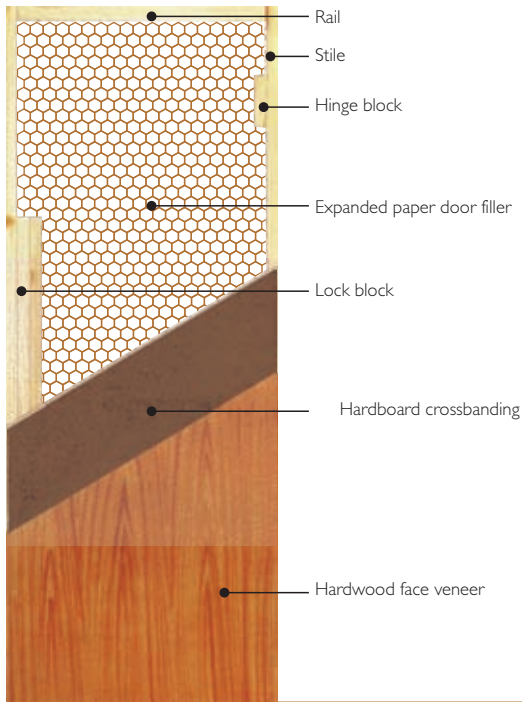

**Specification:** Constructed from kiln dried (kd) softwood frame with lock block on one side only, hinge blocks on opposite side. Core of expanded paper. Supplied with exposed softwood edges (ee), one concealed hardwood edge (1ce) or two concealed hardwood edges (2ce). Edges are post lipped.

**Available in the following finishes:** hardboard, catafoil, sapele veneer, gaboon veneer, deep moulded

**Thickness:** 40mm

**S.A.B.S.:** Suitable for light duty dry interior applications (ld-di)

**Mass:** Approx 16 kg

## SEMI SOLID DOOR (G-CORE/ EXPANDED PAPER)

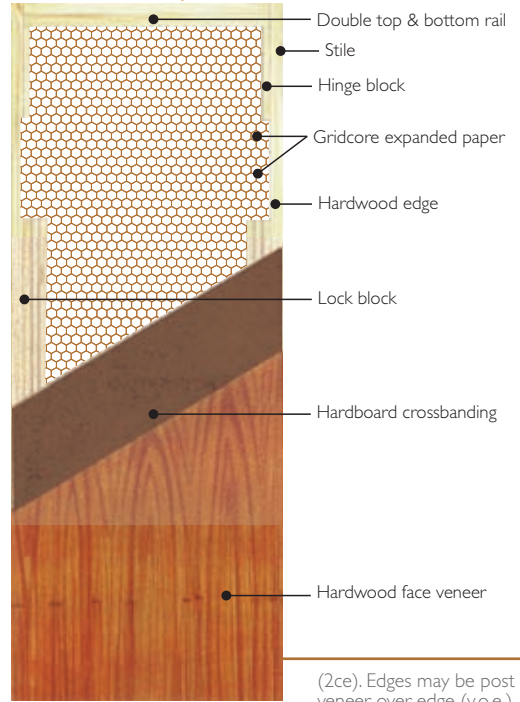

**Specification:** Balanced construction from kiln dried (kd) frame with double top and bottom rails with lock blocks and hinge blocks on both sides. Grid core of composite board/expanded paper. Supplied with exposed fingerjointed hardwood edges (ee), one concealed hardwood edge (1ce) or two concealed hardwood edges

(2ce). Edges may be post lipped or veneer over edge (v.o.e.)

**Available in the following finishes:** hardwood, sapele veneer, gaboon veneer or exotic veneers on request.

**Thickness:** 40mm

**S.A.B.S.:** Suitable for medium duty dry interior applications (md-di)

**Mass:** Approx. 21 kg

## SOLID LAMINATED DOOR

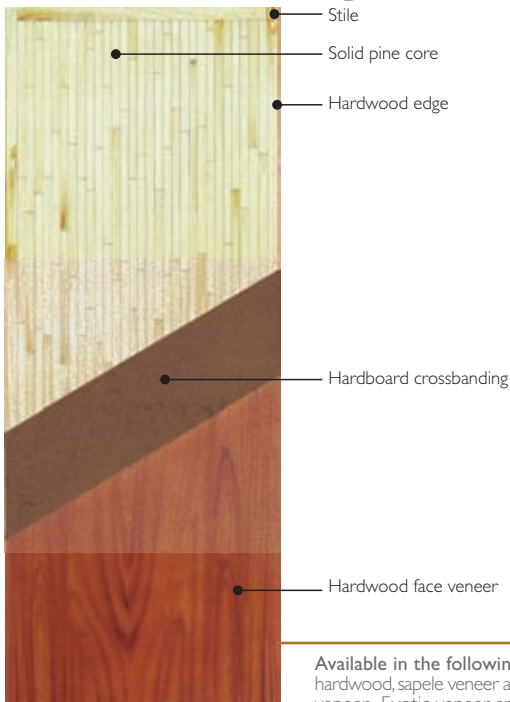

**Specification:** Constructed from laminated kiln dried (kd) softwood core. 6mm composite board crossbanding. Supplied with hardwood edge strips post lipped.

**Available in the following finishes:** hardwood, sapele veneer and gaboon veneer. Exotic veneer and formica available on request.

**Thickness:** 40mm

**S.A.B.S.:** Suitable for heavy duty dry interior applications (hd-di)

**Mass:** Approx 34 kg

## SOLID LAMINATED SEMI-EXTERIOR DOOR

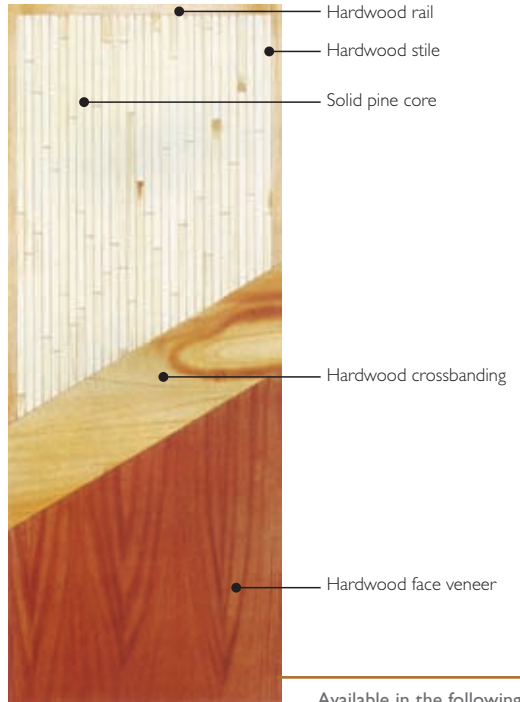

**Specification:** Constructed from hardwood framing and laminated kiln dried (kn) softwood core. 4mm hardwood crossbanding. Supplied with exposed hardwood stiles only. Glued throughout with weather and boil proof adhesive.

**Available in the following finishes:** sapele veneer and gaboon veneer.

**Thickness:** 40 mm

**S.A.B.S.:** Suitable for heavy duty semi-exterior applications (hd-se)

**Mass:** Approx. 34 kg



# BB<sup>®</sup> DOORS



BB<sup>®</sup> doors perform excellently in exterior applications. BB<sup>®</sup> doors are perfectly balanced and may be used any way up or hung on any side. The BB<sup>®</sup> Stable door is completely reversible allowing any stable configuration. The laminated construction ensures that a BB<sup>®</sup> door is resistant to warp or twist. Hardwood and Saligna BB<sup>®</sup> doors meet performance criteria for heavy duty class I exterior doors — the highest possible exterior classification for exterior doors in South Africa.

## SA PINE BB<sup>®</sup> FINGER JOINTED



**Specification:** Constructed from kiln dried (kd) softwood frame with double top and bottom rails, hinge blocks and lock blocks on both sides. S.A. pine finger jointed tongue and groove v jointed boarding glued to frame on both sides with weather and boil proof adhesive. Supplied raw fine sanded.

Available in full height and stable pattern

**Stock sizes:** 813 x 2032 x 40mm (F/height and stable)

**S.A.B.S.:** Suitable for medium duty semi exterior applications (md-se)

**Mass:** Approx 28 kg

## SALIGNA BB<sup>®</sup> FINGER JOINTED



**Specification:** Constructed from kiln dried (kd) hardwood and softwood frame with double top and bottom rails, hinge blocks and lock blocks on both sides. Saligna finger jointed tongue and groove v jointed boarding glued to frame on both sides with weather and boil proof adhesive. Supplied raw fine sanded.

Available in full height and stable pattern.

**Stock Sizes:** 813 x 2032 x 40mm (F/height and stable)

**S.A.B.S.:** Suitable for heavy duty class I exterior applications (hd — class I ext).

**Mass:** Approx 30kg

## HARDWOOD BB<sup>®</sup>



**Specification:** Constructed from kiln dried (kd) hardwood and softwood frame with double top and bottom rails, hinge blocks and lock blocks on both sides. Hardwood tongue and groove v jointed boarding glued to frame on both sides with weather and boil proof adhesive. Supplied raw fine sanded.

Available in full height and stable pattern.

**Stock Sizes:** 813 x 2032 x 40mm (F/height and stable)

762 x 2032 x 40mm (f/height only)

**S.A.B.S.:** Suitable for heavy duty class I exterior applications (hd — class I ext).

**Mass:** Approx 30kg

## HARDWOOD BB<sup>®</sup> SQUARE JOINTED



**Specification:** Constructed from kiln dried (kd) hardwood frame with double top and bottom rails, hinge blocks and lock blocks on both sides. Hardwood tongue and groove square jointed boarding glued to frame on both sides with weather and boil proof adhesive. Supplied raw fine sanded.

Available in full height and stable pattern.

**Stock Sizes:** 813 x 2032 x 40mm

**S.A.B.S.:** Suitable for heavy duty class I exterior applications (hd — I ext).

**Mass:** Approx. 30kg

## BB<sup>®</sup> DOOR CONSTRUCTION

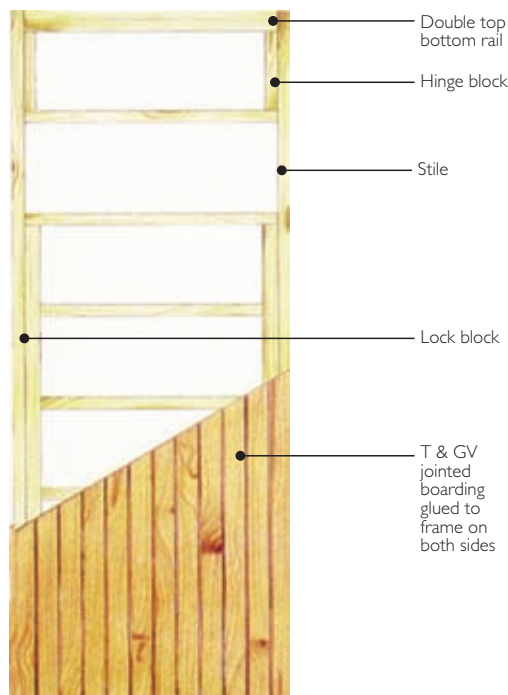

**Specification:** Showing S.A. Pine sub frame with double top and bottom rails, hinge blocks and lock blocks on both sides. Tongue and groove boarding in either v joint or square joint glued to frame on both sides with weather and boil proof adhesive. BB<sup>®</sup> doors in stable pattern are fully reversible.

Available in standard sizes.

Can be manufactured to order in non standard sizes.

	<b>LD- LIGHT DUTY</b> Domestic Use
	<b>MD- MEDIUM DUTY</b> Domestic, Commercial & Industrial Use
	<b>HD- HEAVY DUTY</b> High traffic or Security use
	<b>DI- DRY INTERIOR</b> Dry controlled conditions
	<b>SE- SEMI EXTERIOR</b> Not exposed to direct weather (sun or moisture)
	<b>CLASS I EXT</b> May be directly exposed to weather once sealed

# EXTERIOR DOORS

New Code	Old Code	Barcode	Product Description
FIRST IMPRESSIONS® PANEL CONTEMPORARY			
82380	82380	6009502900072	Techline II Horizontal Sapele
82312	82381	6009502900027	Techline II Diagonal Wideboard
82320	82320	6009502900034	Techline II Horizontal Wideboard 1200mm
82330	82330	6009502900041	Techline II Diagonal Wideboard 1200mm
82340	82340	6009502900058	Techline Horizontal Fire (Purpose made)
82375	82370	6009502900065	Techline II MD Sapele Horizontal

New Code	Old Code	Barcode	Product Description
FIRST IMPRESSIONS® ENTRANCE PANEL SECURITY			
80005	80005	6009502900089	6 Panel Security Half Grill
80027	80027	6009502900096	8 Panel Security Full Grill
81019	81049C	6009502900102	SA Pine 6 Panel Security Stained
81018	81049A	6009502900119	SA Pine 8 Panel Security Stained
81082	81082	6009502900126	Clifton Arched Rose Jewel
81011	81011	6009502900133	SA Pine 4 Panel Cottage
81001	81001	6009502900140	SA Pine 6 Panel Townhouse

New Code	Old Code	Barcode	Product Description
FIRST IMPRESSIONS® ENTRANCE ORNATE			
80001	80001	6009502900157	Azalea Stained
80017	80017	6009502900164	King Protea Stained
80009	80009	6009502900171	Protea Panel
71021	○1021	6009502900188	Classic Elephant
71022	○1022	6009502900195	Classic Lion

New Code	Old Code	Barcode	Product Description
FIRST IMPRESSIONS® ENTRANCE PANEL DOORS			
80025	80025	6009502900201	Cape Dutch
80405	80025T	6009502900218	Cape Dutch 103 Stiles
80014	80014	6009502900225	6 Panel Vertical
80003	80003	6009502900232	6 Panel Horizontal
80013	80013	6009502900249	6 Panel Townhouse
80401	80013T	6009502900256	6 Panel Townhouse 103 Stiles
80010	80010	6009502900263	15 Panel
71005	○1005	6009502900270	2 Panel Entrance
80016	80015S	6009502900287	2 Panel Stable
71002	○1002	6009502900294	6 Panel Entrance
71001	○1001	6009502900300	8 Panel Entrance
80008	80006S	6009502900317	8 Panel Stable
71003	○1003	6009502900324	10 Panel Entrance

New Code	Old Code	Barcode	Product Description
TECHFORM® FRAMED & LEDGED			
71401	81102T	6009502900331	Hardwood F&L Open Back
71402	81102G	6009502900348	Hardwood F&L Braced SABS
81101	81101T	6009502900355	Hardwood F&L 762mm
81106	81105T	6009502900362	Hardwood F&L Pairs RMS 1610mm 103 Stile
81124	81119T	6009502900379	Hardwood F&L Plyback 103 Stile
81125	81126T	6009502900386	Hardwood F&L Flushback 762mm 103 Stile
81128	81127T	6009502900393	Hardwood F&L Flushback 103 Stile
81127	81127BT	6009502900409	Hardwood F&L Flushback Pairs RMS 1610mm 103 Stile
81107	81107G	6009502900416	Hardwood F&L Stable, Braced
81108	81107T	6009502900423	Hardwood F&L Stable 103 Stiles
81119	81120T	6009502900430	Hardwood F&L Stable Plyback 103 Stile
81120	81128T	6009502900447	Hardwood F&L Stable Flushback 103 Stile
81150	81150	6009502900454	SA Pine F&L
81117	81118	6009502900461	HWD 1/2 F&L 1/2 9 Light Stable Plyback open in
81118	81118Q	6009502900478	HWD 1/2 F&L 1/2 9 Light Stable Plyback open out
81113	81113P	6009502900485	HWD 1/2 F&L 1/2 3 Light Stable Plyback open in
81114	81114P	6009502900492	HWD 1/2 F&L 1/2 3 Light Stable Plyback open out
81122	81117P	6009502900508	HWD 1/2 F&L 1/2 9 Light Plyback
81123	81117T	6009502900515	HWD 1/2 Glass 1/2 F&L Plyback 103 Stile

New Code	Old Code	Barcode	Product Description
TECHFORM® BB DOOR®			
82070	82070	6009502900522	SA Pine BB Fingerjointed Stained
82106	82106	6009502900539	Hardwood BB Fullboard
82112	82112	6009502900546	Hardwood BB Fingerjointed
82108	82108	6009502900553	Hardwood BB Fullboard Stable
82115	82115	6009502900560	Hardwood BB Fingerjointed Stable
82013	82013	6009502900577	SA Pine BB Fingerjointed 762mm
82014	82014	6009502900584	SA Pine BB Fingerjointed 762x1981mm
82012	82012	6009502900591	SA Pine BB Fingerjointed
82008	82008	6009502900607	SA Pine BB Fingerjointed Stable
82220	82220	6009502900614	Saligna BB Fullboard
82202	82202	6009502900621	Saligna BB Fingerjointed
82203	82203	6009502900638	Saligna BB Fingerjointed Stable
82228	82228	6009502900645	Saligna BB Fullboard Stable
82060	82060	6009502900652	SA Pine BB Teak Stain Smart Edge Stained SABS

New Code	Old Code	Barcode	Product Description
TECHFORM® FRAMED GLAZED DOORS			
80091	80091	6009502900669	Techform Heidelberg
81405	81406E	6009502900683	Techform I8 Light
81406	81406B	6009502900690	Techform I8 Light with Beads
81410	81406G	6009502900706	Techform I8 Light Glazed
81412	81418G	6009502900713	Techform I8 Light pairs RMS 1610mm Glazed

New Code	Old Code	Barcode	Product Description
FIRST IMPRESSIONS® ENTRANCE GLAZED DOORS			
80070	80070	6009502900720	Happy Unglazed Beaded
80071	80071	6009502900737	Happy Unglazed Beaded Pairs RMS 1210mm
80072	80072	6009502900744	Happy Unglazed Beaded Pairs RMS 1610mm
80079	80079	6009502900751	Crystal Rose
80080	80080	6009502900768	Rose Jewel
80082	80082	6009502900775	Downham Daisy
80084	80084	6009502900782	Kent
71030	○1030	6009502900799	Kentucky
71031	○1031	6009502900805	Carolina
80073	80073	6009502900812	Burnham York Clear Leaded

New Code	Old Code	Barcode	Product Description
SOLID LAMINATED FIRE DOORS			
92602	92601F	6009502900829	SL Sapele Fire 40
92640	92638F	6009502900836	SL Albany Fire 40
92641	92639F	6009502900843	SL Regency Fire 40
92653	92652F	6009502900850	SL TDM Redwood Fire 40
92702	92701F	6009502900867	SL Hardboard Fire 40

New Code	Old Code	Barcode	Product Description
MEDIUM DUTY GROOVED DOORS			
91756	91750A	6009502900874	MD TDM Redwood EE 8 Panel Arched
91758	91750E	6009502900881	MD TDM Redwood EE Groove
91760	91750H	6009502900898	MD TDM Redwood EE Horizon
91761	91750S	6009502900904	MD TDM Redwood EE Shield
91762	91750T	6009502900911	MD TDM Redwood EE Tao
91763	91750Z	6009502900928	MD TDM Redwood EE Morocco
91764		6009502900935	MD TDM Redwood EE Mayfair
91765		6009502900942	MD TDM Redwood EE Balmoral
91766		6009502900959	MD TDM Redwood EE Richmond
91767		6009502900966	MD TDM Redwood EE Grosvenor

New Code	Old Code	Barcode	Product Description
FIRST IMPRESSIONS® EBONY			
80601		6009502902793	TDM Ebony Lion
80602		6009502902809	TDM Ebony Elephant
80603		6009502902816	TDM Ebony Symphony
80604		6009502902823	TDM Ebony Nguni
80640		6009502902885	TDM Ebony Protea

# INTERIOR DOORS

New Code	Old Code	Barcode	Product Description
INTERIOR HOLLOWCORE CATAFOIL & VENEERED			
91750	91750	6009502900973	HC TDM Redwood EE
91754	91754	6009502900980	HC TDM Redwood 1CE 762mm
91751	91751	6009502900997	HC TDM Redwood 1CE
91755	91755	6009502901000	HC TDM Redwood 2CE 762mm
91752	91752	6009502901017	HC TDM Redwood 2CE
91757	91750B	6009502901024	HC TDM Redwood EE Barcelona
91759	91750M	6009502901031	HC TDM Redwood EE Madrid
91104	91104	6009502901048	HC Sapele EE
91107	91107	6009502901055	HC Sapele 1CE 762mm
91108	91108	6009502901062	HC Sapele 1CE
91112	91112	6009502901079	HC Sapele 2CE
91803	91803	6009502901086	HC Catafoil EE 762mm
91804	91804	6009502901093	HC Catafoil EE
91805	91804B	6009502901109	HC Catafoil EE Barcelona
91806	91804M	6009502901116	HC Catafoil EE Madrid

New Code	Old Code	Barcode	Product Description
INTERIOR FLUSH PANEL DEEP MOULDED			
91093	91093	6009502901123	DM 4 Panel Arched
91100	91100	6009502901130	DM Boston 3 Panel
91082	91082	6009502901147	DM Cape Dutch
91087	91082A	6009502901154	DM Cape Dutch 762mm
71102	92721	6009502901161	DM Cape Dutch Fire
91085	91085	6009502901178	DM Coventry
91089	91085A	6009502901185	DM Coventry 762mm
71104	92723	6009502901192	DM Coventry Fire NR
91099	91099	6009502901208	DM Oslo 1 Panel
91096	91096	6009502901215	DM Monaco 6 Panel Unequal
91083	91083	6009502901222	DM Townhouse
91088	91083A	6009502901239	DM Townhouse 762mm
91092	91092	6009502901246	DM 2 Panel Elegance
91101	91092A	6009502901253	DM 2 Panel Elegance 762mm
71105	92720	6009502901260	DM Elegance Fire MS

New Code	Old Code	Barcode	Product Description
HOLLOWCORE PANEL			
91070	91070	6009502901277	HC Albany
91071	91071	6009502901284	HC Albany 762mm
91026	91026	6009502901291	HC Regency
91027	91026A	6009502901307	HC Regency 762mm
91045	91045	6009502901314	HC Tuscan
91000	91000	6009502901321	HC Hardboard EE 686mm
91003	91003	6009502901338	HC Hardboard EE 762mm
91004	91004	6009502901345	HC Hardboard EE
91011	91011	6009502901352	HC Hardboard 2CE 762mm
91012	91012	6009502901369	HC Hardboard 2CE
91005	91004B	6009502901376	HC Hardboard Barcelona EE
91006	91004M	6009502901383	HC Hardboard Madrid EE

New Code	Old Code	Barcode	Product Description
DEEP MOULDED VENEER/GLAZED			
71050	○1050	6009502901390	Cape Dutch 6 Light Glazed
71051	○1051	6009502901406	Coventry 2 Light Etched
91077	91077	6009502901413	DM 4 Panel Arched HWD Veneered
91075	91075	6009502901420	DM Townhouse HWD Veneered
91076	91076	6009502901437	DM Elegance HWD Veneered

New Code	Old Code	Barcode	Product Description
INTERIOR SEMI-SOLID CLASSIC			
92403	92403	6009502901482	SS Sapele 762mm
92404	92404	6009502901499	SS Sapele
92442	92442	6009502901505	SS TDM Redwood 762mm
92443	92443	6009502901512	SS TDM Redwood
92488	92488	6009502901529	SS Hardboard with H/W Stiles 762mm
92486	92486	6009502901536	SS Hardboard with H/W Stiles
92494	92494	6009502901543	SS Cherry
92495	92495	6009502901550	SS Oak
92496	92496	6009502901567	SS Oak Heritage





All TDM doors are manufactured in accordance with the SABS Standard Specification for Wooden Doors - SABS 545-1989. This specification lays down a rigid set of performance criteria against which each door is tested and approved before the SABS mark can be applied to the door.



TDM (Pty) Ltd has been assessed and certified as meeting the requirements of ISO 9001:2000. Certificate ZA 06/0415.0



All TDM doors are covered by a one year guarantee, subject to the installation, maintenance and handling conditions as set out in our General Sales Conditions, details of which are available on application to TDM at [www.tdm.co.za](http://www.tdm.co.za)

## DISTRIBUTORS



**Area Contact Company City Tel Fax E- Mail**

**Head Office Odette/Caressa**  
TDM Doors  
Pietermaritzburg  
033 397 7200  
033 397 7273  
info@tdm.co.za

**Area Contact Company City Tel Fax E-mail**

**Purpose Made Sunitha**  
TDM Doors  
Pietermaritzburg  
033 397 7200  
086 688 1189  
sunitha@tdm.co.za

**Area Contact Company City Tel Fax Mobile**

**Western Cape Retief Rautenbach**  
Montague Garden  
Cape Town  
021 551 3781  
021 551 3921  
082 902 6136

**Area Contact Company City Tel Fax Mobile**

**Namibia Pieter Slabber**  
CA Industrials  
Windhoek  
00 264 61 232 475  
00 264 61 242 139  
00 264 81 128 8777

**Area Contact Company City Tel Fax Mobile**

**Gauteng/Botswana Philip Wood**  
Esstee Timbers  
Johannesburg  
083 676 2887  
086 688 9159  
082 888 0311

**Area Contact Company City Tel Fax Mobile**

**Free State Andy Gous**  
Achiever Sales  
Bloemfontein  
051 522 2147  
051 522 2147  
083 544 4877

**Area Contact Company City Tel Fax Mobile**

**Eastern Cape PE Pat Murphy**  
Murmac Agencies  
Port Elizabeth  
041 451 4488  
041 453 6560  
082 557 9416

**Area Contact Company City Tel Fax Mobile**

**EL/ Transkei MP Agencies**  
Mark Parry  
East London  
043 721 3549  
086 696 0414  
082 801 2589

TDM (Pty) Limited  
11 Chesterfield Road, Willowton, 3201  
PO Box 1173, Pietermaritzburg, 3200,  
KwaZulu-Natal, South Africa

Tel: 033 397 7200 (International) +27 33 297 7200  
Fax: 033 397 7273 (International) +27 33 397 7273  
Reg. No. 1964/04302/07

Website: <http://www.tdm.co.za>  
E-mail (Local): [info@tdm.co.za](mailto:info@tdm.co.za)  
(Export): [export@tdm.co.za](mailto:export@tdm.co.za)



## GLAZING

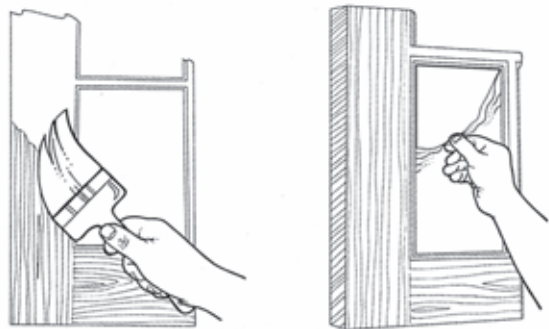

## SAFETY GLASS

TDM Doors are glazed with 4mm (1/8 ) Tempered Safety Glass. Toughened glass is tested in accordance with British Standard BS6206.

Glass is film wrapped for easy painting.

- ¥ Paint, stain or varnish the door and allow to dry completely.
- ¥ Using a sharp trimming knife, carefully cut around the glass aperture.
- ¥ Peel off masking film from glass surface.

## STORAGE AND HANDLING

- Once the door has been delivered and sealed, it should be properly stored flat on a level surface in a dry, well-ventilated area and not stored on edge or on end.
- Doors should be stacked on bearers to spread the load.
- Avoid storing in direct sunlight
- Always handle with care so as not to scratch or mark the surface or edge of the door:

## WARRANTY

All TDM doors are covered by a one year guarantee, subject to the installation, maintenance and handling conditions as set out in our General Sales Conditions, details of which are available on application to TDM at [www.tdm.co.za](http://www.tdm.co.za)

## GLOSSARY

<b>ICE</b>	Concealed edge (flush doors with one stile concealed with hardwood lip).
<b>2CE</b>	Concealed edges (flush doors with both stiles concealed with hardwood lips).
<b>BEADED CUT OUTS</b>	Opening provided to flush doors with glazing beads for site glazing.
<b>BRACES</b>	Timber members fitted diagonally between the rails and stiles of a framed door (usually after hanging). Braces must be fitted to rise from the hanging stile outwards to counteract the door raking (sagging).
<b>CALIBRATING</b>	The process of sanding the surfaces of a flush door blank to give it perfectly true and even faces before overveneering.
<b>CORE</b>	The internal structure of a flush door:
<b>CROSS BANDING</b>	(Flush doors) the structural skin of the flush door, consisting either of hardboard or 3mm thick hardwood veneer.
<b>E/E</b>	Exposed edges
<b>EXTERIOR DOOR</b>	Door designed to cope with normal exterior atmosphere. Note that exterior doors are not designed to cope with continuous direct sunlight or driving rain. Please contact your TDM representative for the most suitable exterior door for your project.
<b>FACE VENEER</b>	The decorative veneer of a flush door covering the cross banding.
<b>FL &amp; B</b>	Framed ledged and batten door:
<b>FLB &amp; B</b>	Framed, ledged, battened and braced door:
<b>FLUSH BACK</b>	(Framed doors) term used when both batten and middle rail and bottom rail are concealed by a ply wood covering fitting flush with the top rail and stiles of a framed door:
<b>H &amp; C RAIL</b>	(Flush doors) extra rail provided to give solid fixing point for hat and coat hook.
<b>HC</b>	Hollow core door:
<b>HINGE BLOCK</b>	(Flush doors) extra timber added to give strength and to spread stresses at the hinge position.
<b>HW STILES</b>	Hardwood stiles (flush doors with exposed stiles made from hardwood).
<b>INTERIOR DOOR</b>	Door designed for interior use only.
<b>LOCK BLOCK</b>	(Flush doors) additional timber provided to add strength round the lock position and solid fixing points for lock furniture.
<b>OB</b>	Open Back framed doors term used to indicate that the battens of a framed door are exposed on the inside.
<b>PLAIN CUT OUTS</b>	Opening provided to flush doors to accept ventilation grilles.
<b>PLY BACK</b>	Framed doors term used when ply wood covering is fixed hard against the inside of the battens of a framed door (all rails left exposed).
<b>POST LIPPED</b>	Flush doors with hardwood edges applied after veneering.
<b>PRE-LIPPED</b>	Flush doors with hardwood edges applied after veneering. Semi solid and solid laminated doors.
<b>RMS</b>	Rebated meeting stiles normally used on all types of doors when paired.
<b>ROUNDED STILES</b>	Used on all types of doors when hung on floor springs to swing. Both hanging and meeting stiles may be rounded or the hanging stiles may be rounded and the meeting stiles square on the same door.
<b>SL</b>	Exterior quality solid laminated door
<b>SL</b>	Solid Laminated door:
<b>SS</b>	Semi solid door:
<b>VOE</b>	Veneer over edges. Flush doors when the face veneer is applied to the edges of a prelipped calibrated door blank.
<b>WEATHER BOARD</b>	Moulded timber section fitted to the bottom of exterior doors to prevent water running under the bottom of door: